

A20①B-②1E③-BU

工業開關 > Φ30A20開關控制元件

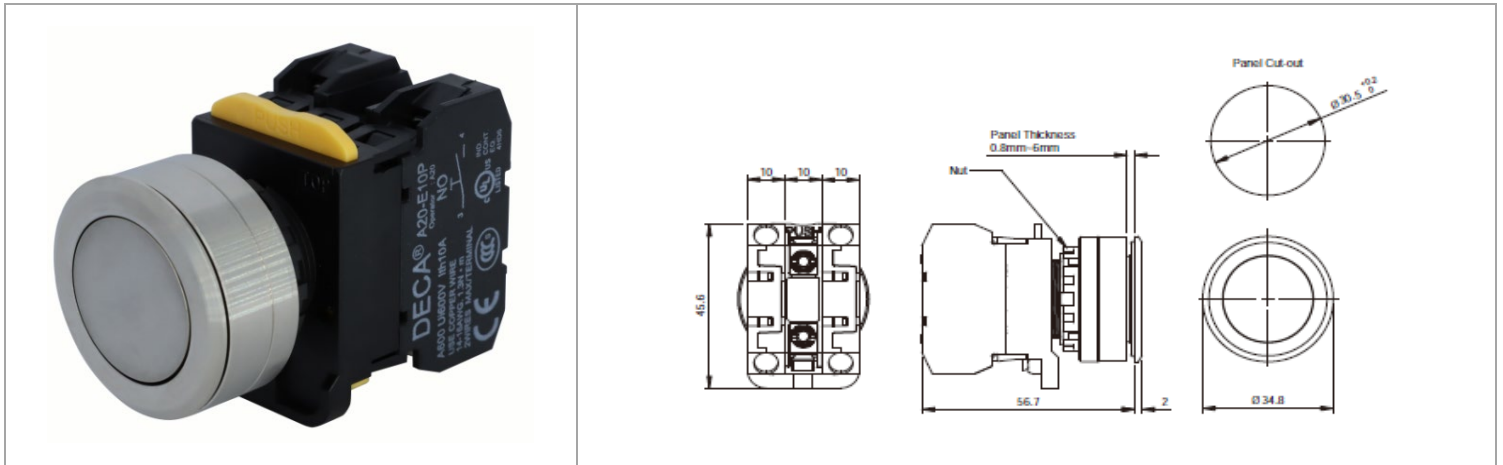

目錄僅供參考，實際規格仍依照產品工程圖面為準

產品介紹 Product Description

基本信息 Additional Information

產品系列 Series	M22 - ø22mm
產品種類 Function	模組式 Module
產品型式 Type	按鈕開關 Pushbutton Switch
面框材料① Bezel Material①	5: 鋁, 6: 鋁黑色, 7: 不鏽鋼 5: Aluminum, 6: Dark Aluminum, 7: Stainless steel
產品頭型 Shape	平頭 Flush
動作類型② Operator②	M: 復歸, A: 保持 M: Momentary, A: Maintained
接點塊③ Block③	10: 1NO, 01: 1NC, 20: 2NO, 02: 2NC, 11: 1NO+1NC
電壓 Voltage	-
顏色 Color	-
線徑 Wire Diameter	14~16AWG

產品規格 Product Specification

Rated Insulation Voltage (Ui)		600V			
Rated Thermal Current (Ith)		10A			
Rated Operational Voltage (Ue)		24V	120V	240V	380V
AC 50/60HZ	Resistive Load (AC-12) (Ie)	10A	10A	6A	2A
	Inductive Load (AC-15) (Ie)	10A	6A	3A	1.9A
DC	Resistive Load (DC-12) (Ie)	8A	2.2A	1.1A	-
	Inductive Load (DC-13) (Ie)	4A	1.1A	0.55A	-

汙染等級 Degree of Pollution	3
接觸阻抗 Contact resistance	100mΩ max (at 1A, DC 6~8V)
絕緣阻抗 Insulation resistance	100MΩ max (at DC 500V)
耐電壓 Dielectric Strength	AC 2500, 50/60Hz for 1min
機械壽命 Mechanical Life	5,000,000 operations
電氣壽命 Electrical Life	100,000 operations
電氣耐久性 Electrical Durability	1,000,000 cycles, AC-15, 230V/1A, 3600 cyc/hr, load factor 0.5 1,000,000 cycles, DC-13, 24V/0.6A, 3600 cyc/hr, load factor 0.5
抗衝擊-誤動作 Shock Resistance - Operating Extremes	100 m/s ²
抗衝擊-耐久性 Shock Resistance - Operating Extremes	1000 m/s ²
耐振動-誤動作 Vibration Resistance - Operating Extremes	5~55Hz, 單振幅 0.5mm 5 to 55Hz, Amplitude 0.5mm
耐振動-耐久性 Vibration Resistance - Damage Limits	30Hz, 單振幅 1.5mm 30Hz, Amplitude 1.5mm
容許操作頻率-機械 Operating Frequency	瞬時MAX 60次/min (參考) Instantaneous Maximum 60 operations per 1 min

安裝說明 Assembly

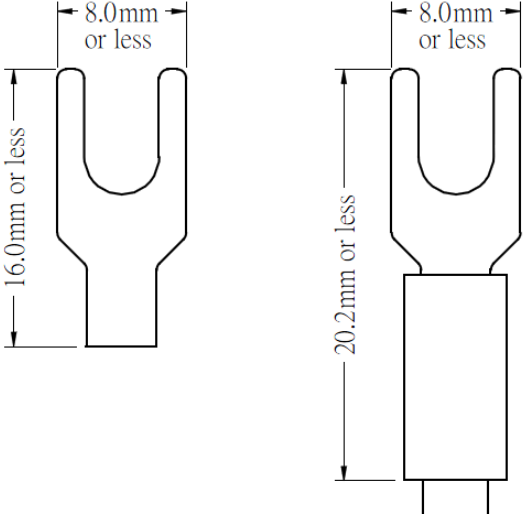
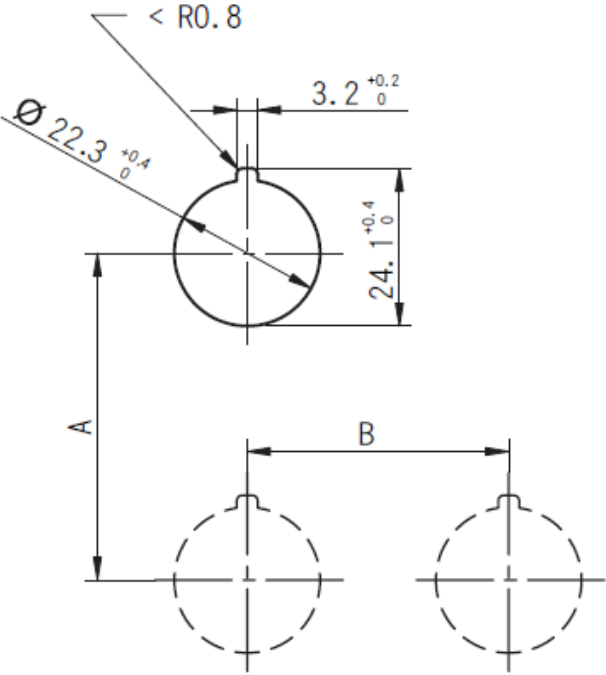
端子外型 Crimp Terminals Appearance	安裝孔尺寸 Mounting Hole Layout
	
面板厚度 Panel Thickness	0.8~12 mm
安裝轉矩 (牙環) Mounting Torque	2 N.m

安全認證 Certificates

Certification Mark	
Approved Standards	IEC 60947-1, IEC 60947-5, GB/T 14048.5, UL508, CSA C22.2