

AP2B-A1E①②

工業開關 > Φ22AP2插拔式開關

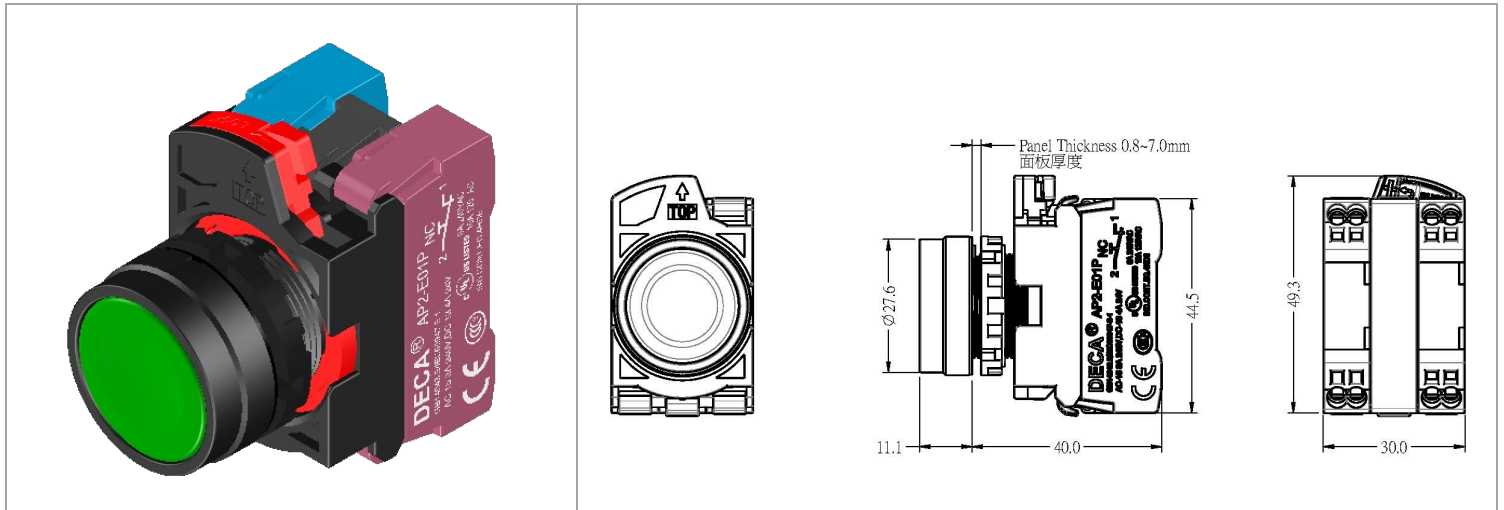

目錄僅供參考，實際規格仍依照產品工程圖面為準

產品介紹 Product Description

基本信息 Additional Information

產品系列 Series	M22
產品種類 Function	模組式 Module
產品型式 Type	按鈕開關 Pushbutton Switch
面框材料 Bezel Material	塑膠 Plastic
產品頭型 Shape	平頭 Flush
動作類型 Operator	保持 Maintained
接點塊 ① Block ①	10:1NO, 20: 2NO,30:3NO, 01:1NC, 02:2NC,03:3NC, 11:1NO1NC, 12:1NO2NC, 21:2NO1NC
顏色 ② Color ②	B:黑色, R:紅色, G:綠色, S:藍色, Y:黃色, W:白色 B:Black, R:Red, G:Green, S:Blue, Y:Yellow, W:White
重量 Weight	45g
線徑 Wire Diameter	14~20AWG

產品規格 Product Specification

產品規格 Product Specification						
Rated Insulation Voltage (Ui)		600V				
Rated Thermal Current (Ith)		10A				
Rated Operational Voltage (Ue)		12V	24V	120V	240V	380V
AC 50/60HZ	Resistive Load (AC-12) (Ie)	10A	10A	10A	6A	3.8A
	Inductive Load (AC-15) (Ie)	10A	10A	6A	3A	1.9A
Rated Operational Voltage (Ue)		12V	24V	125V	250V	-
DC	Resistive Load (DC-12) (Ie)	10A	10A	2.2A	1.1A	-
	Inductive Load (DC-13) (Ie)	10A	5.8A	1.1A	0.55A	-
儲存溫度 Storage Temperature		-40°C to +85°C				
操作溫度 Operating Temperature		-25°C to +70°C				
操作濕度 Operating Humidity		45% to 85% RH				
防護等級 Degree of Protection		IP66				

汙染等級 Degree of Pollution	3
接觸阻抗 Contact resistance	100mΩ max (at 1A, DC 6~8V)
絕緣阻抗 Insulation resistance	100MΩ max (at DC 500V)
耐電壓 Dielectric Strength	AC 2500, 50/60Hz for 1min
機械壽命 Mechanical Life	500,000 operations
電氣壽命 Electrical Life	100,000 operations
電氣耐久性 Electrical Durability	1,000,000 cycles, AC-15, 230V/2A, 3600 cyc/hr, load factor 0.5 1,000,000 cycles, DC-13, 24V/1.5A, 3600 cyc/hr, load factor 0.5
抗衝擊-誤動作 Shock Resistance - Operating Extremes	150 m/s ²
抗衝擊-耐久性 Shock Resistance - Operating Extremes	1000 m/s ²
耐振動-誤動作 Vibration Resistance - Operating Extremes	10~500Hz, 單振幅 0.35mm, 加速度 50 m/s ² 10 to 500Hz, Amplitude 0.35mm, Acceleration 50 m/s ²
耐振動-耐久性 Vibration Resistance - Damage Limits	10~500Hz, 單振幅 0.35mm, 加速度 50 m/s ² 10 to 500Hz, Amplitude 0.35mm, Acceleration 50 m/s ²
容許操作頻率-機械 Operating Frequency	瞬時MAX 60次/min Instantaneous Maximun 60 operations per 1 min

安裝說明 Assembly

端子外型 Crimp Terminals Appearance	安裝孔尺寸 Mounting Hole Layout
端子規格 Crimp Terminals Spect	0.50~1.5 mm ² (8mm)
面板厚度 Panel Thickness	0.8~7 mm
安裝轉矩 (牙環) Mounting Torque	2 N.m

安全認證 Certificates

<p>Certification Mark</p>	
<p>Approved StandardS</p>	<p>IEC 60947-5, GB/T 14048.5, GB/T 6994(IEC 60092), UL1059, UL508(CSA C22.2 No.14).</p>