

MPX315-1005xxK

端子台 > 歐規端子台

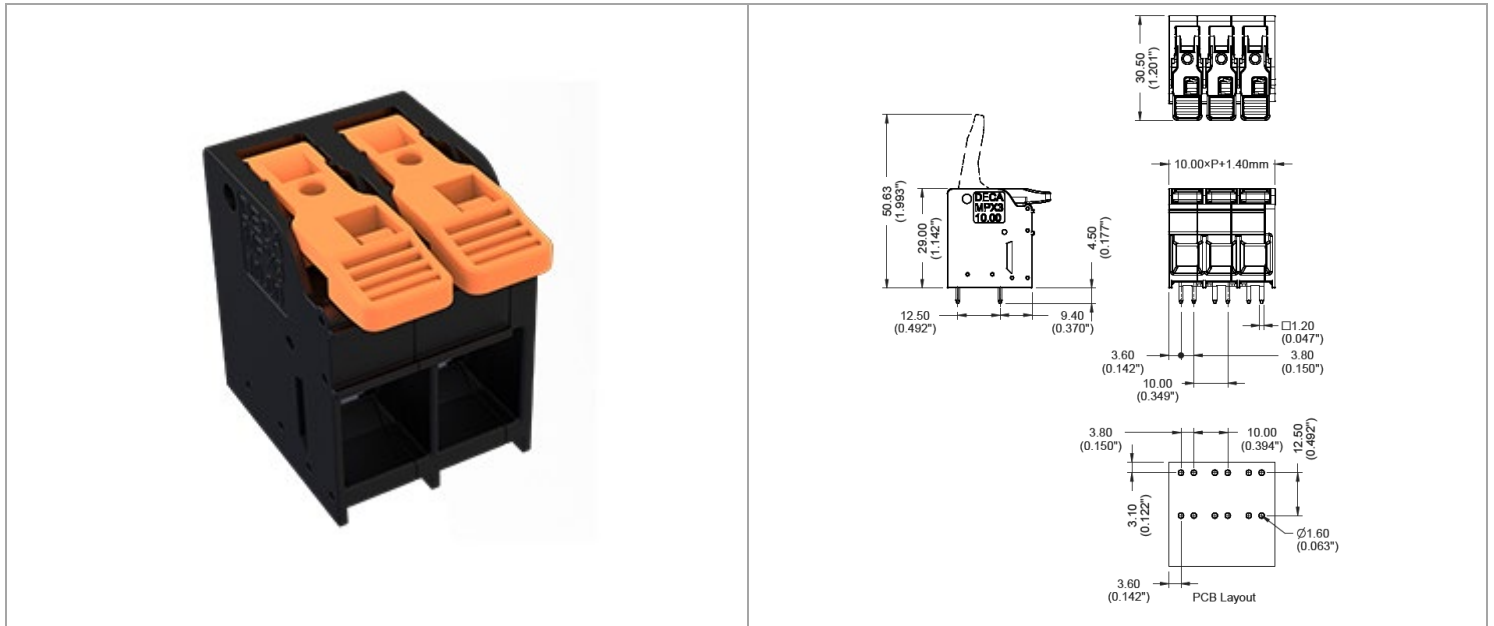

目錄僅供參考，實際規格仍依照產品工程圖面為準

產品介紹 Product Description

PCB Terminal Blocks , Push in, Pitch : 10.00 mm /Product data IEC: 400V / 76A / Product data UL: 300V, 51A

一般資料 General information

產品類型 Category	PCB Terminal Block
Conductor entry angle to the PCB	0°
產品間距 (mm) Pitch (mm)	10.00
產品顏色 Color	Black (default)
接線方式 Connection method	Push in
固定方式 Type of locking	Without
焊接方式 Soldering method	Wave soldering
產品長度 (mm) Length (mm)	10.00xP + 1.40
產品寬度 (mm) Width (mm)	25
產品高度 (mm) Height (mm)	29
出腳長度 (mm) Solder pin length (mm)	4.5
出腳尺寸 (mm) Solder pin dimensions (mm)	1.2×1.2
焊孔直徑 (mm) PCB hole diameter (mm)	1.6
位數 Number of positions	1~8
產品層數 Number of levels	1

材料資訊 Material information

絕緣材料 Insulating material	PA66
絕緣材料組別 Insulating material group	I
耐燃等級，符合UL94 Flammability rating according to UL94	V0
導體材料 Contact material	Copper alloy
導體表面鍍層 Plating of contact surface	tin plated

連接數據-IEC Connection data-IEC

額定電流 (A) Rated current (A)	76
額定電壓 (II/2)(V) Rated voltage (II/2)(V)	800
額定電壓 (III/2)(V) Rated voltage (III/2) (V)	400
額定電壓 (III/3)(V) Rated voltage (III/3)(V)	400
額定沖擊電壓 (II/2)(KV) Rated impulse voltage (II/2)(KV)	6
額定沖擊電壓 (III/2)(KV) Rated impulse voltage (III/2)(KV)	6
額定沖擊電壓 (III/3)(KV) Rated impulse voltage (III/3)(KV)	6
最小實心導線橫截面積 (mm ²) Conductor cross section solid, min. (mm ²)	0.75
最大實心導線橫截面積 (mm ²) Conductor cross section solid, max. (mm ²)	16.0
最小軟導線橫截面積 (mm ²) Conductor cross section flexible, min. (mm ²)	0.75
最大軟導線橫截面積 (mm ²) Conductor cross section flexible, max. (mm ²)	16.0
軟導線橫截面積，最小管型裸端子 (mm ²) Conductor cross section flexible, with ferrule without plastic sleeve, min. (mm ²)	0.75
軟導線橫截面積，最大管型裸端子 (mm ²) Conductor cross section flexible, with ferrule without plastic sleeve, max. (mm ²)	16.0
軟導線橫截面積，最小管狀預絕緣端子 (mm ²) Conductor cross section flexible, with ferrule with plastic sleeve, min. (mm ²)	0.75
軟導線橫截面積，最大管狀預絕緣端子 (mm ²) Conductor cross section flexible, with ferrule with plastic sleeve, max. (mm ²)	10.0
具有相同截面積的二根最小軟導線橫截面積，最小管狀預絕緣TWIN端子 (mm ²) 2 conductors with same cross section flexible, with TWIN ferrule with plastic sleeve min. (mm ²)	0.75
具有相同截面積的二根最小軟導線橫截面積，最大管狀預絕緣TWIN端子 (mm ²) (mm ²) 2 conductors with same cross section flexible, with TWIN ferrule with plastic sleeve max. (mm ²)	4
一字螺絲刀規格 (刃厚__x刃寬__)(mm) Slotted screwdriver size (Blade thickness x Width)(mm)	本系列免工具
剝線長度 (mm) Stripping Length (mm)	17~18

連接數據-UL Connection data-UL

額定電壓 (UL/CUL標準B組)(V) Rated voltage (UL/CUL use group B)(V)	300
額定電流 (UL/CUL標準B組)(A) Rated current (UL/CUL use group B)(A)	51
額定電壓 (UL/CUL標準C組)(V) Rated voltage (UL/CUL use group C)(V)	150
額定電流 (UL/CUL標準C組)(A) Rated current (UL/CUL use group C)(A)	51
額定電壓 (UL/CUL標準D組)(V) Rated voltage (UL/CUL use group D)(V)	300
額定電流 (UL/CUL標準D組)(A) Rated current (UL/CUL use group D)(A)	10
最小實心導線(AWG)，符合UL/CUL Min. solid wire connection (AWG) acc. to UL/CUL	18

最大實心導線(AWG)，符合UL/CUL Max. solid wire connection AWG acc. to UL/CUL	6
最小多芯導線(AWG)，符合UL/CUL Min. stranded wire connection AWG acc. to UL/CUL	18
最大多芯導線(AWG)，符合UL/CUL Max. stranded wire connection AWG acc. to UL/CUL	6

環境與安全 Environment & Safety

Storage temperature, min. (°C)	-25
Storage temperature, max. (°C)	55
Max. relative humidity during storage	70%
備註：以上三欄位為我司端子未來之標準儲存溫度及濕度	
最高工作溫度 (°C) Operating temperature. max (°C)	105
最低工作溫度 (°C) Operating temperature. min (°C)	-40

Packaging information

Type of packaging (2 pole)	Box
pieces per package (2 pole)	待查詢
Type of packaging (3 pole)	Box
pieces per package (3 pole)	待查詢
Type of packaging (4 pole)	Box
pieces per package (4 pole)	待查詢

認證 Approvals

